

STANDARD PRODUCTS

DESCRIPTION

The SR50-31x series of single-pole quintuple-throw wide band (0.1-20.0GHz) PIN diode switches employ a series/shunt configuration in a microstrip transmission line circuit. They are compact in size, light weight, featured with field replaceable connectors, and offered in medium (-312) and high (-313) isolation models.

SCHEMATIC

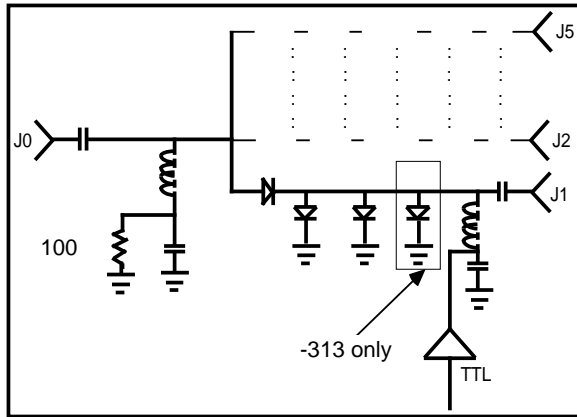

SP5T SWITCH

SERIES SR50-31x

Reflective Series/Shunt

1 μsec. Switching Speed

ELECTRICAL PERFORMANCE

CHARACTERISTIC	WITH DRIVER		WITHOUT DRIVER	
	MAX.	TYP.	MAX.	TYP.
Switching Speed (1)	1.0μs	0.5μs	(2)	(2)
Transition Time (3)	0.5μs	0.1μs	(2)	(2)
Power Handling (CW or peak)	+30 dBm	+33 dBm	+30 dBm	+33 dBm
Positive Supply	5V± 2% 110 mA max		30 mA (Iso.)	10 mA
Negative Supply (4)	-12V to -15V 70 mA max		-30 mA (Loss)	-20 mA
Control Impedance	TTL (1 unit loads max)		N/A	
Control Logic (4)	see Options on back		see Supply requirements	

MODEL	CHARACTERISTIC	See Note (5)	FREQUENCY (GHz)							
			V	U	L	S	C	X	P	K
			0.1-0.5	0.5-1.0	1.0-2.0	2.0-4.0	4.0-8.0	8.0-12.4	12.4-18.0	18.0-20.0
SR50-312	INSERTION LOSS (dB max)	TYP.	0.8	0.5	0.6	0.8	1.3	1.8	2.1	3.0
		MAX	1.2	0.8	1.0	1.2	1.7	2.2	2.5	3.4
	VSWR (max)		1.40	1.35	1.35	1.40	1.60	1.75	2.0	2.2
	ISOLATION (dB min)		65	60	60	60	55	50	50	45
SR50-313	INSERTION LOSS (dB max)	TYP.	1.0	0.6	0.8	1.0	1.5	1.9	2.3	3.2
		MAX	1.5	1.0	1.2	1.4	1.9	2.3	2.7	3.6
	VSWR (max)		1.40	1.35	1.35	1.4	1.6	1.75	2.0	2.2
	ISOLATION (dB min)		70	70	75	75	70	65	65	60

- (1) Turn on time is the time interval between 50% of the control voltage and 90% of the detected RF. Turn off time is the time interval between 50% of the control voltage and 10% of the detected RF. Switching Speed is defined as the slower of the two times (usually the turn on time).
- (2) Depends upon driver supplied by the user.
- (3) Rise time is the time required for the detected RF to transition between 10% and 90% of its final value. Fall time is the time required for the detected RF to transition between 90% and 10% of its initial value. Transition time is defined as the slower of the two times (usually the Rise time).
- (4) Setting more than one RF port at a time to the loss state causes excessive current in the common arm bias return.
- (5) Operating frequency range for narrower bandwidth unit(s) is specified by an option code that is composed of two letters. The first letter designates the starting frequency band and the second one designates the ending frequency band. Frequency code is not required for standard unit that covers 0.1 to 20.0 GHz ("VK").



ENVIRONMENTAL RATINGS

Temperature:

Operating.....55°C to +85°C
 Non-operating.....65°C to +125°C

Humidity:

MIL-STD-202C, Method 103B,
 Cond. B (96 hrs. at 95%)

Vibration:

MIL-STD-202C, Method 204A,
 Cond. B (0.06" double amplitude
 or 15G, whichever is less)

Altitude:

MIL-STD-202C, Method 105C,
 Cond. B (50,000ft)

Temp Cycling:

MIL-STD-202C, Method 105C,
 Cond. D, 5 cycles

Shock:

MIL-STD-202C, Method 213,
 Cond. B (750G, 6ms)

OPTIONS

LOGIC:

OPTION NUMBER	LOGIC DESCRIPTION	INDIVIDUAL PORT CONTROL		DECODED			PORT CONDITION
		1	0	E3	E2	E1	
(STD) (4)	INVERTING	ISO.	LOSS	X			
L2 (4)	NON INVERTING	LOSS	ISO.				
L3	BINARY DECODED	X		0	0	0	ALL ISO.
				0	0	1	J1=LOSS
				⋮	⋮	⋮	⋮
				1	0	1	J5=LOSS

CONTROL CONNECTOR:
 (STD).....Solder Pin
 C2.....SMC-M

FREQUENCY:
 (STD).....0.1 to 20.0 GHz
 Two Letter Code, see note 5
 for detail

DRIVER:
 (STD).....With Driver
 D2.....Without driver

OUTLINE

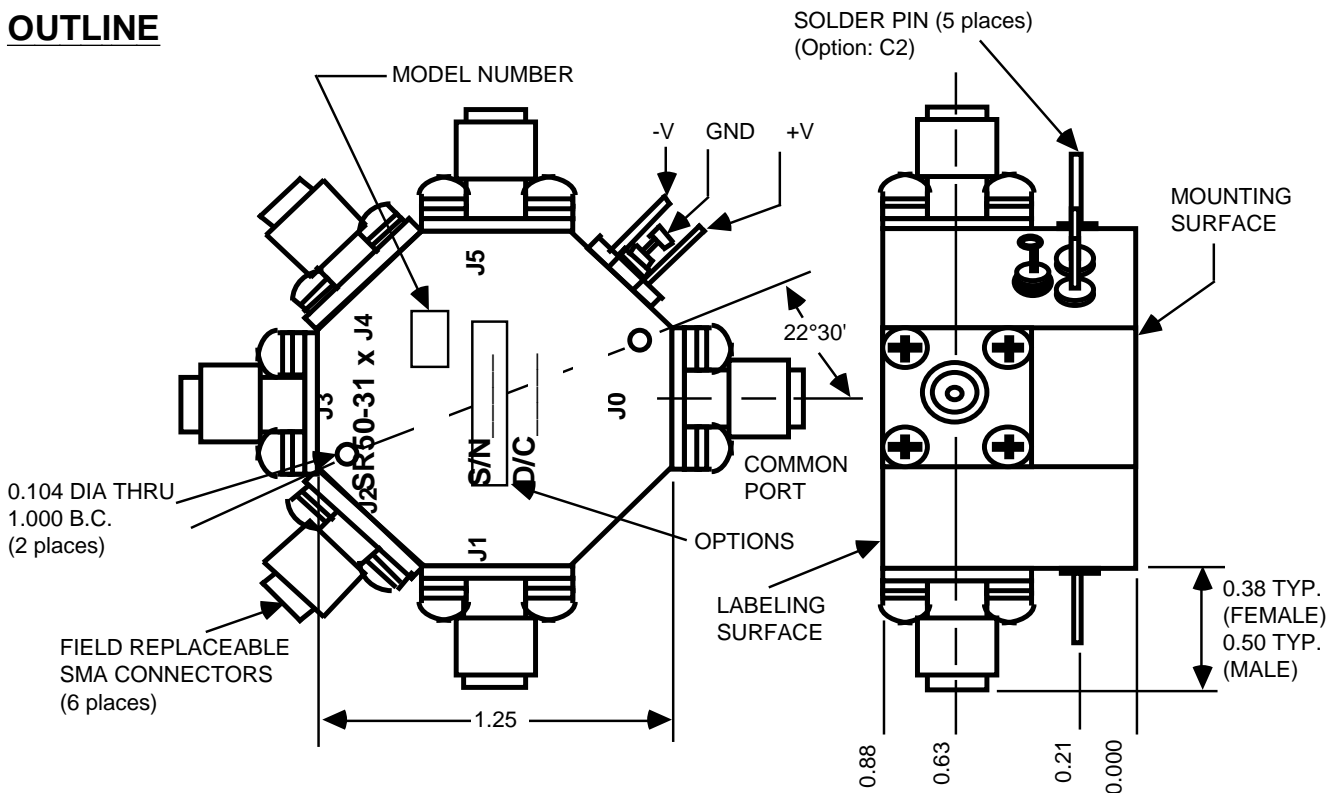

Custom Microwave Components, Inc.
 44249 Old Warm Springs Blvd.
 Fremont, California 94538
 510-651-3434

