

# STANDARD PRODUCTS

## DESCRIPTION

The SR70-33x series of reflective single-pole septuple-throw PIN diode switches employ a series/shunt microstrip transmission line configuration controlled by an integral TTL compatible driver. They are compact in size, light weight, featured with field replaceable connectors, and offered in medium (-332) and high (-333) isolation models. Video transient filtering is optional.

## SP7T SWITCH

**SERIES SR70-33x**

Reflective Series/Shunt

25 nsec. Switching Speed

## ELECTRICAL PERFORMANCE

CHARACTERISTIC	WITH DRIVER	
	MAX.	TYP.
Switching Speed (1)	25ns	20ns
Transition Time (2)	20ns	10ns
Power Handling (CW or peak)	+30 dBm	+33 dBm
Positive Supply	5V ± 2% 180 mA max	
Negative Supply (3)	See Option 120 mA max	
Control Impedance	TTL (1 unit loads max)	
Control Logic (3)	see Options on back	
Video Transients (4)	see Options on back	

## SCHEMATIC

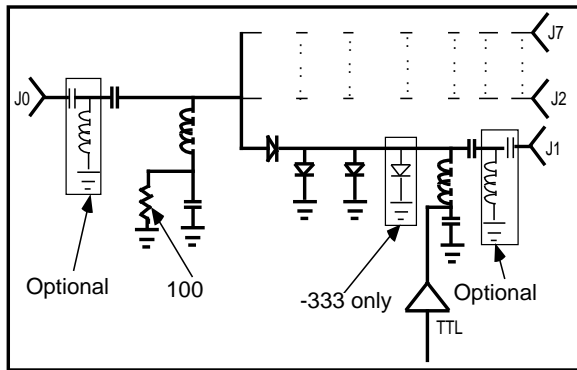

MODEL	CHARACTERISTIC		FREQUENCY (GHz)			
			S	C	X	P
		See Note (5)	S	C	X	P
			2.0-4.0	4.0-8.0	8.0-12.4	12.4-18.0
SR70-332	INSERTION LOSS (dB max)	TYP.	1.0	1.5	2.1	3.2
		MAX	1.4	1.9	2.5	3.6
	VSWR (max)		1.40	1.60	1.75	2.0
	ISOLATION (dB min)		60	55	50	50
SR70-333	INSERTION LOSS (dB max)	TYP.	1.2	1.6	2.3	3.4
		MAX	1.6	2.0	2.7	3.8
	VSWR (max)		1.4	1.6	1.75	2.0
	ISOLATION (dB min)		75	70	65	65

- (1) Turn on time is the time interval between 50% of the control voltage and 90% of the detected RF. Turn off time is the time interval between 50% of the control voltage and 10% of the detected RF. Switching Speed is defined as the slower of the two times (usually the turn on time).
- (2) Rise time is the time required for the detected RF to transition between 10% and 90% of its final value. Fall time is the time required for the detected RF to transition between 90% and 10% of its initial value. Transition time is defined as the slower of the two times (usually the Rise time).
- (3) Setting more than one RF port at a time to the loss state causes excessive current in the common arm bias return.
- (4) Measured into a 50 ohms with a 150mHz B.W. oscilloscope. Typically 2V p-p max. unfiltered and 50mV p-p max. with filtering. Filtering will typically add 0.3dB insertion loss per filter in a transmission path.
- (5) Operating frequency range for narrower bandwidth unit(s) is specified by an option code that is composed of two letters. The first letter designates the starting frequency band and the second one designates the ending frequency band. Frequency code is not required for standard unit that covers 2.0 to 18.0 GHz ("SP").



## ENVIRONMENTAL RATINGS

### Temperature:

Operating.....-55°C to +85°C  
 Non-operating.....-65°C to +125°C

### Humidity:

MIL-STD-202C, Method 103B,  
 Cond. B (96 hrs. at 95%)

### Vibration:

MIL-STD-202C, Method 204A,  
 Cond. B (0.06" double amplitude  
 or 15G, whichever is less)

### Altitude:

MIL-STD-202C, Method 105C,  
 Cond. B (50,000ft)

### Temp Cycling:

MIL-STD-202C, Method 105C,  
 Cond. D, 5 cycles

### Shock:

MIL-STD-202C, Method 213,  
 Cond. B (750G, 6ms)

## OPTIONS

### LOGIC:

OPTION NUMBER	LOGIC DESCRIPTION	1	0
(STD) (3)	<b>INVERTING</b>	<b>ISO.</b>	<b>LOSS</b>
L2 (3)	NON INVERTING	LOSS	ISO.

### CONTROL CONNECTOR:

(STD).....Solder Pin  
 C2.....SMC-M

### FREQUENCY:

(STD).....2.0 to 18.0 GHz  
 Two Letter Code, see note 5  
 for detail.

### VIDEO TRANSIENT:

(STD).....None  
 F2.....All Ports  
 F3.....Common Port  
 Only  
 F4.....Non-Common Ports  
 Only

### NEGATIVE SUPPLY

(STD).....-12V  
 N2.....-15V

## OUTLINE

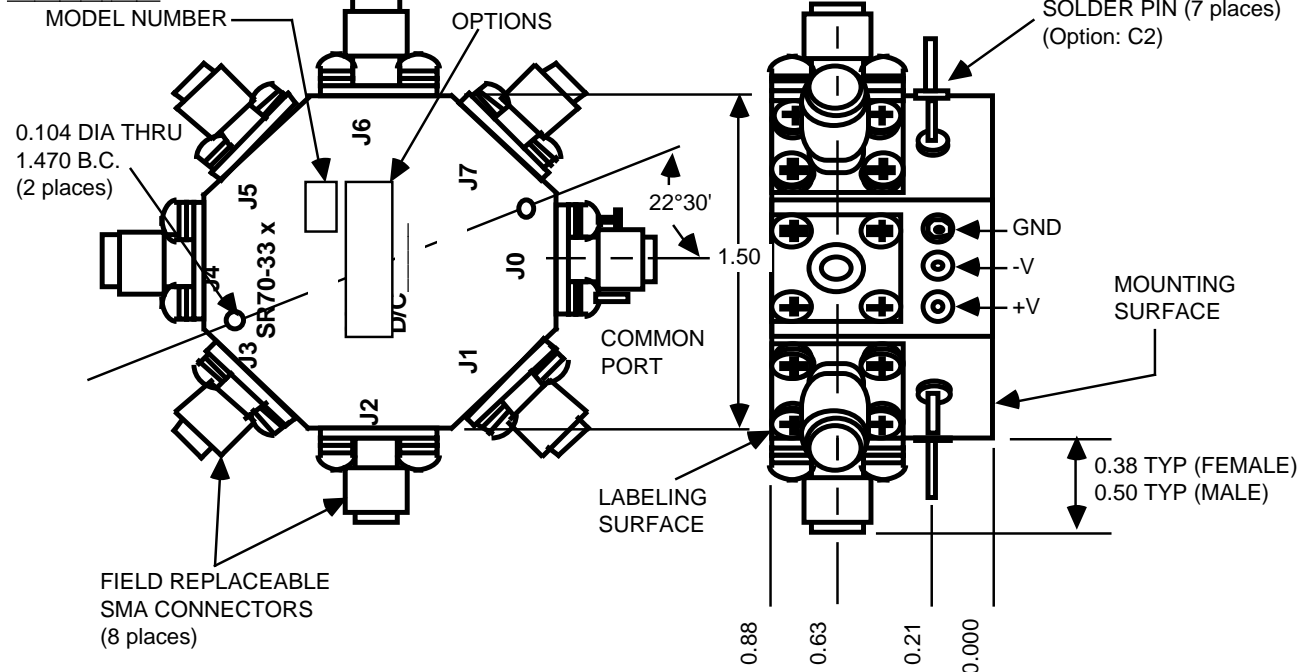

Custom Microwave Components, Inc.



44249 Old Warm Springs Blvd.  
 Fremont, California 94538  
 510-651-3434