

STANDARD PRODUCTS

DESCRIPTION

The SN30-33x series of high-speed wide-band (2.0-18.0 GHz) non-reflective single-pole triple-throw PIN diode switches, employs a series/shunt configuration in a microstrip transmission line circuit. They are compact in size, light weight, featured with field replaceable connectors, integral TTL compatible drivers, and offered in medium (-332), high (-333), and extra-high (-334) isolation models. Video transient filtering is optional.

SCHEMATIC

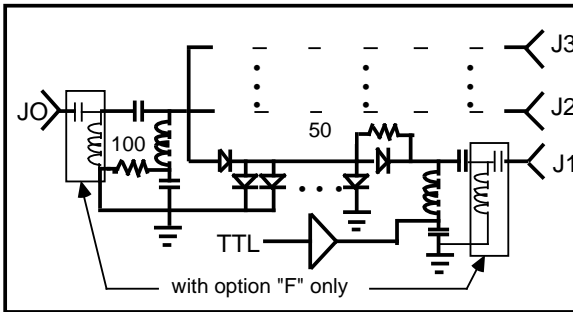

SP3T SWITCH

SERIES SN30-33x

Non-Reflective Series/Shunt

25 nsec. Switching Speed

ELECTRICAL SPECIFICATIONS

CHARACTERISTIC	WITH DRIVER	
	MAX.	TYP.
Switching Speed (1)	25 ns (7)	20 ns
Transition Time (2)	20 ns (7)	10 ns
Power Handling (CW or peak)	+30 dBm	+33 dBm
Positive Supply	5V ± 2% @ 80 mA max	
Negative Supply (3)	(4) @ 95 mA max	
Control Impedance	TTL (2 unit loads max)	
Control Logic (3)	(4)	
Video Transients (5)	(4)	

R.F. PERFORMANCE

MODEL	CHARACTERISTIC	FREQUENCY (GHz) (See Note 6)				
		S	C	X	P	
SN30-332	INSERTION LOSS (dB max)	TYP.	1.1	1.6	2.1	2.5
		MAX.	1.5	2.0	2.5	2.9
	ISOLATION (dB min)	60	55	50	50	
SN30-333	INSERTION LOSS (dB max)	TYP.	1.3	1.8	2.3	2.7
		MAX.	1.7	2.2	2.7	3.1
	ISOLATION (dB min)	75	70	65	65	
SN30-334	INSERTION LOSS (dB max)	TYP.	1.5	2.0	2.5	2.9
		MAX.	1.9	2.4	2.9	3.3
	ISOLATION (dB min)	85	80	80	80	
ALL MODELS	VSWR {On/Off} (max)	1.50	1.70	1.70	2.00	

- "Turn-On Time"/"Turn-Off Time" is the time between the 50% point of the control voltage and the 90% or the 10% point of the detected RF, respectively. "Switching Speed" is defined as the slower of the two times (usually the Turn-On Time).
- "Rise Time"/"Fall Time" is the time required for the detected RF to transition between the 10% and 90% points or the 90% and 10% points, respectively. "Transition Time" is defined as the slower of the two times (usually the Rise Time).
- Setting more than one RF port at a time to the insertion loss state can cause excessive power dissipation in the common arm bias return network and may result in switch failure.
- See "Options" on back of page.
- Measured into a 50 ohms with a 150MHz B.W. oscilloscope. Typically 2V p-p max. unfiltered and 50mV p-p max. with filtering. Filtering will typically add 0.3dB insertion loss per filter in a transmission path.
- Operating frequency range for narrower bandwidth unit(s) is specified by a two letter option code where the first letter designates the frequency band within which the lowest operating frequency is located and the second letter designates the frequency band within which the highest operating frequency is located. A frequency code is not required for the standard unit that covers 2.0 to 18.0 GHz ("SP").
- Measured by switching a single port between the Insertion Loss and Isolation states. Toggling/Commutating Speed, likewise that for switches with decoded drivers, is measured by switching between two ports and is specified at 50 nsec. max.



ENVIRONMENTAL RATINGS

Temperature:

Operating.....-55°C to +85°C
 Non-operating.....-65°C to +125°C

Humidity:

MIL-STD-202C, Method 103B,
 Cond. B (96 hrs. at 95%)

Vibration:

MIL-STD-202C, Method 204A,
 Cond. B (0.06" double amplitude
 or 15G, whichever is less)

Altitude:

MIL-STD-202C, Method 105C,
 Cond. B (50,000ft)

Temp Cycling:

MIL-STD-202C, Method 105C,
 Cond. D, 5 cycles

Shock:

MIL-STD-202C, Method 213,
 Cond. B (750G, 6ms)

OPTIONS

LOGIC:

OPTION CODE	LOGIC TYPE	CONTROL STATUS			PORT STATUS
		E3	E2	E1	
L3	BINARY DECODED	x	0	0	ALL ISO.
		x	0	1	J1=LOSS
		x	1	0	J2=LOSS
		x	1	1	J3=LOSS
L2 (4)	NON INVERTING	0			ISO.
		1			LOSS
(STD) (4)	INVERTING	0			LOSS
		1			ISO.

CONTROL CONNECTOR:

(STD).....Solder Pin
 C2.....SMC-M

FREQUENCY:

(STD).....2.0 to 18.0 GHz
 Two Letter Code, see note 5
 for detail.

VIDEO TRANSIENT:

(STD).....None
 F2.....All Ports
 F3.....Common Port Only
 F4.....Non-Common
 Ports Only

NEGATIVE SUPPLY

(STD).....-12V
 N2.....-15V

OUTLINE

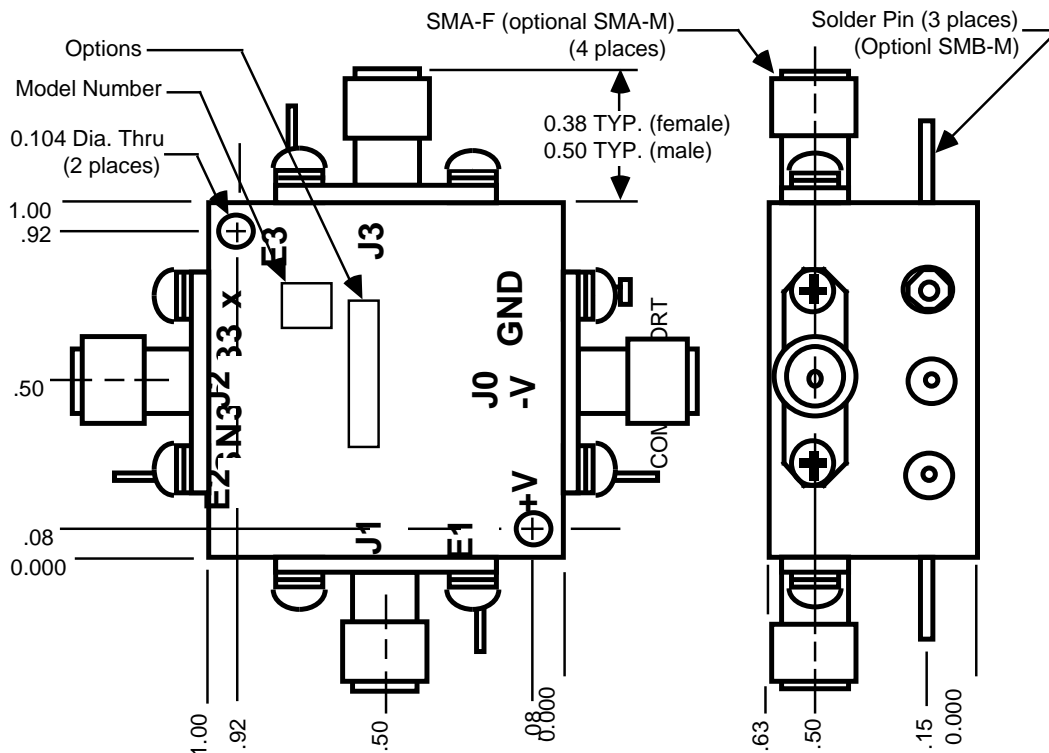

Custom Microwave Components, Inc.
 44249 Old Warm Springs Blvd.
 Fremont, California 94538
 510-651-3434

